

Snowplow Cutting Edge Order Form

Note: When obtaining measurements from your current cutting edge, please measure from the **center line** of the bolt holes. When taking measurements please note that a urethane cutting edge should not overhang the bottom of moldboard by more than the thickness of the cutting edge. When mounting a urethane cutting edge, use your old cutting edge or a piece of steel as a retaining bar, sandwiching the cutting edge against the moldboard.

If you have any questions, please call us at 800-325-5463.

| | |
|---------|------------------|
| Name | _____ |
| Title | _____ |
| Company | _____ |
| PO# | _____ |
| Tel | _____ Ext. _____ |
| Fax | _____ |

Plow Make _____

Plow Model _____

Cutting Edge OEM Part Number _____

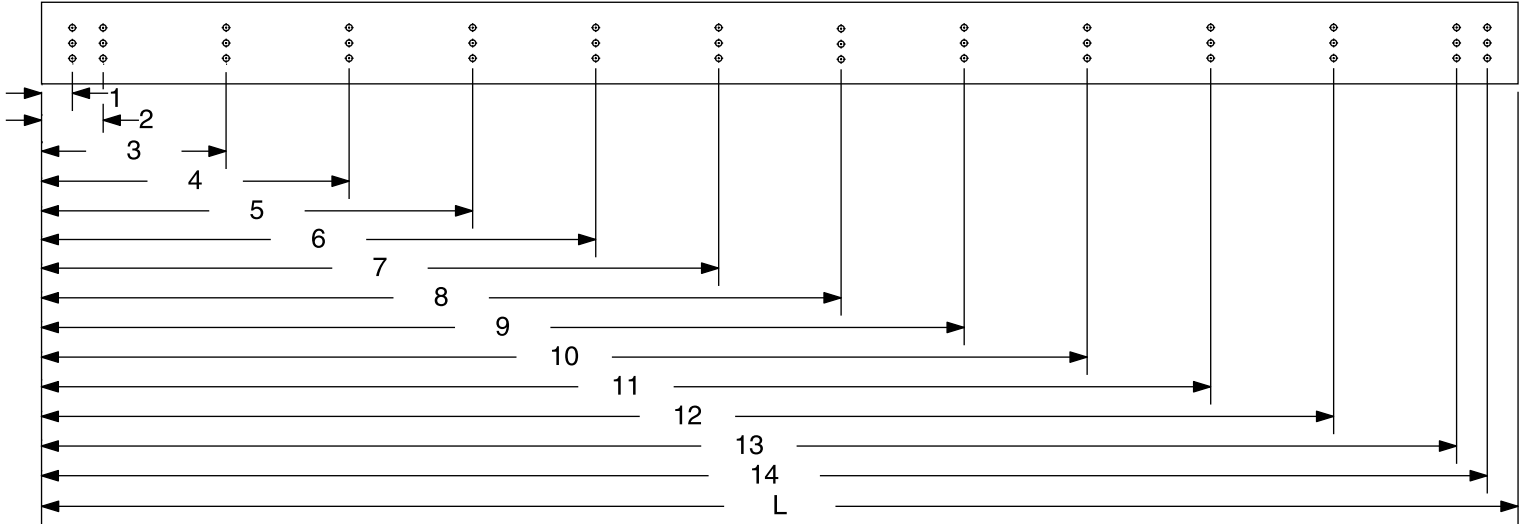

Angled Cutting Edge Options

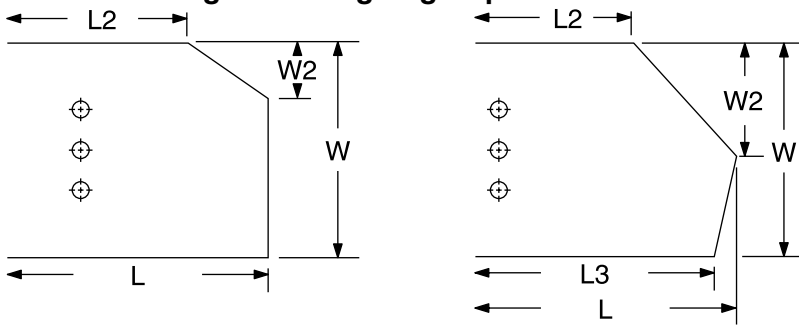

Hole Options

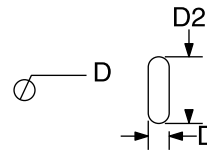

Side Profile

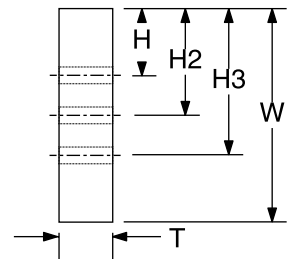

- Overall width of cutting edge (W) _____. If edge of blade is angled (W2) _____.
- Overall length of cutting edge (L) _____. If edge of blade is angled (L2) _____ and (L3) _____ (if applicable).
- Thickness of cutting edge (T) _____.
- Number of bolt hole rows _____.
- Number of holes per row (single, double, or triple punch) _____.
- Please provide the distances for all applicable holes
 (1) _____ (2) _____ (3) _____ (4) _____ (5) _____ (6) _____ (7) _____ (8) _____
 (9) _____ (10) _____ (11) _____ (12) _____ (13) _____ (14) _____ (15) _____ (16) _____
 (17) _____ (18) _____ (19) _____ (20) _____ (21) _____ (22) _____ (23) _____ (24) _____
- Indicate the diameter of the holes (D) _____; if holes have countersink indicate the diameter of countersink _____, and depth of countersink _____. If slots width (D) _____ and length (D2) _____.
- Distance from top of cutting edge to applicable bolt hole(s) (H) _____ (H2) _____ (H3) _____.
- If bevel is desired, please indicate degree of bevel (15°, 30°, or 45°) _____.
- Do require bevel on top and bottom of edge? _____.



Once completed, fax to your FallLine Sales Representative at 775.827.6749

4625 Aircenter Circle • Reno, NV 89502-5992

Tel: 800-325-5463 • Fax: 775-827-6749 • www.fallline.com • info@fallline.com